

Code: 20BS1305

**II B.Tech - I Semester –Regular / Supplementary Examinations
DECEMBER 2023**

**MECHANICS
(MECHANICAL ENGINEERING)**

Duration: 3 hours

Max. Marks: 70

Note: 1. This paper contains questions from 5 units of Syllabus. Each unit carries 14 marks and have an internal choice of Questions.

2. All parts of Question must be answered in one place.

BL – Blooms Level

CO – Course Outcome

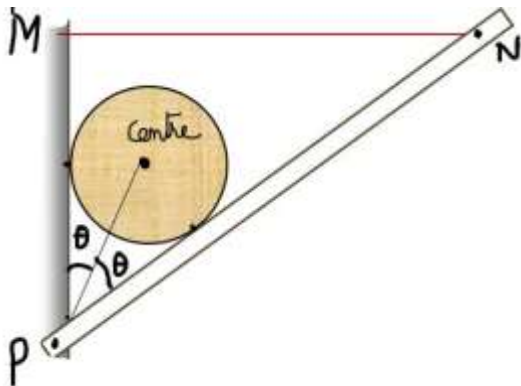
			BL	CO	Max. Marks
UNIT-I					
1	a)	State and Prove Varignon's Theorem.	L2	CO1	4 M
	b)	A circular log weight 1200 N and radius 18 cm is supported by a pair of brackets. One of which is shown in the Fig. The bar PN is hinged at P and held by string MN is 57 cm long to induce minimum tension at MN, determine the value of 2θ for equilibrium. Consider all contact surfaces smooth, also find the value of minimum tension.	L3	CO2	10 M
					
OR					
2	a)	State and Prove parallelogram law of forces.	L2	CO1	4 M
	b)	Three cylinders weighting 100 N each and of 80 mm diameter are placed in a channel of 180 mm width as shown in Fig. Neglecting the friction, determine the reactions at all the	L3	CO2	10 M

points of contact with the channel.

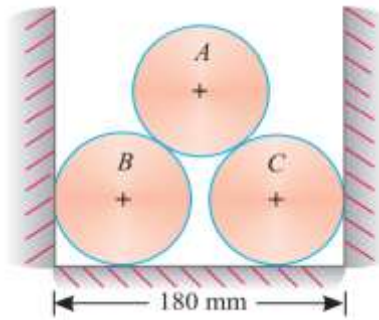

UNIT-II

3 Determine the axial forces in the members of plane truss as shown in the figure L3 CO2 14 M

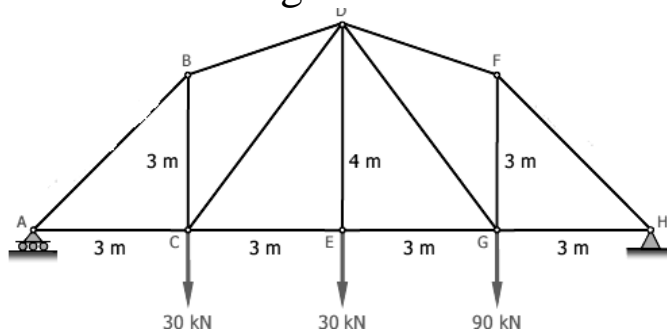

OR

4 a) Determine the least value of P to cause motion to impend rightwards as shown in Fig. The coefficient of friction for all contiguous surfaces is 0.2 and consider pulley as frictionless. L3 CO2 10 M

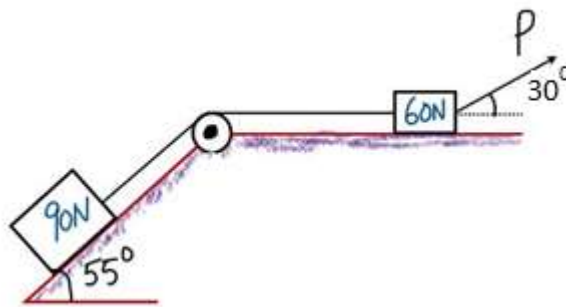

b) Explain angle of repose and prove it is equal to angle of friction. L2 CO1 4 M

UNIT-III

5 a) Determine the location of centroid of shaded area as shown in Fig. L3 CO3 7 M

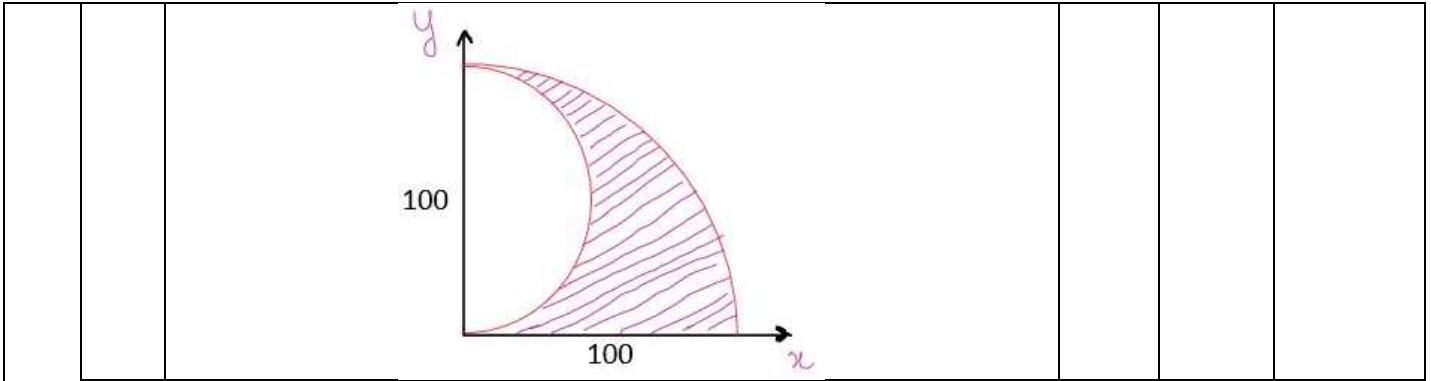

b) Determine the polar moment of inertia of I-section shown in Fig.

L3 CO3 7 M

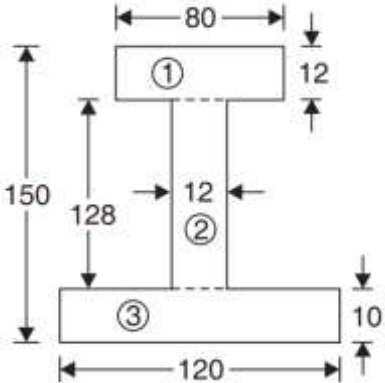

OR

6 a) Determine second moment of hollow rectangular sectional area as shown in Fig.

L3 CO3 7 M

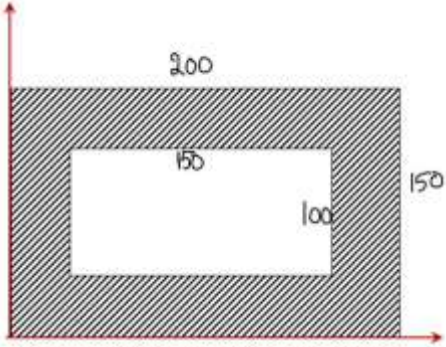

b) Find the centroid of the section shown in Fig.

L3 CO3 7 M

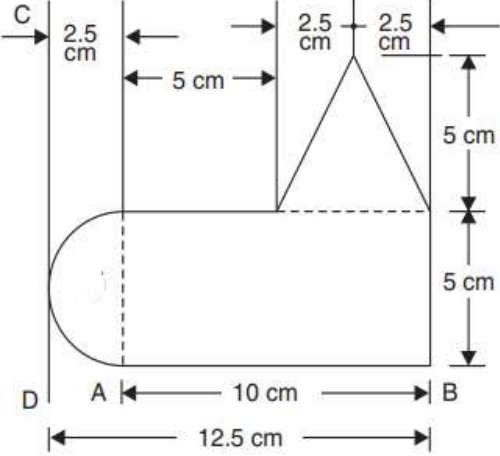

UNIT-IV						
7	A stone is thrown vertically upward with a velocity of 20 m/s from 25 m high tower top. Determine i) time required for stone to reach the ground. ii) velocity of stone during downward movement at the level of point of projection iii) maximum height reached during flight.			L3	CO4	14 M
OR						
8	a)	A particle is projected with a velocity of 40m/sec at an angle of 60° with the horizontal from the foot of an inclined plane of inclination 30° . Find the time of flight and the range on the inclined plane.		L3	CO4	7 M
	b)	A wheel, rotating about a fixed axis at 20 r.p.m., is uniformly accelerated for 70 seconds, during which time it makes 50 revolutions. Find: (i) Angular velocity at the end of this interval, and (ii) Time required for the speed to reach 100 revolutions per minute		L3	CO4	7 M
UNIT-V						
9	a)	Derive the expression for work energy principle in case of rigid bodies.		L2	CO4	4 M
	b)	A weight of 5 N is suspended by a light rope wound round a pulley of weight 50 N and radius 30 cm, the other end of the rope being fixed to the periphery of the pulley. If the weight is moving downwards, determine: (i) Acceleration of the weight 5 N, and (ii) Tension in the string. Take $g = 9.80 \text{ m/s}^2$.		L4	CO4	10 M
OR						
10	a)	A bullet of mass 81 gm and moving with a velocity of 300 m/s is fired into a block of wood and it penetrates to a depth of 10 cm. If the bullet moving with the same velocity, were fired into a similar piece of wood 5 cm thick, with what velocity would it emerge? Also find the force of resistance, assuming it to be uniform.		L4	CO4	10 M
	b)	State D'Alembert's principle.		L2	CO4	4 M